

# Cumulo Key Details

For internal use only



## Freight Pricing Estimates

**\*\*The Lumian manufacturing plant is 245 miles from the Cumulo warehouse in Memphis, Tennessee. Additionally, Lumian's retailers' distribution centers are in the following locations and are the provided distances from the Cumulo warehouse in Memphis:**

- Gainesville, Georgia: 446 miles
- Little Rock, Arkansas: 137 miles
- Loxley, Alabama: 387 miles
- Plant City, Florida: 857 miles
- Wilmer, Texas: 463 miles

### AIR FREIGHT

Air freight requires specialized containers, unit load devices (ULDs), or palletization that fits in the cargo-hold of an airplane. ULDs vary by airline carrier, making air freight a complex shipping option. Air freight requires additional transportation to move shipments to and from airports.

	Base Fee (Up to 250 Pounds)	Direct Carrier Rate per Pound	Fuel Surcharge per Pound	Markup per Pound	Client Price per Pound
<b>Domestic Air Freight (One-pallet Minimum)</b>	\$1,000.00	\$6.15	\$1.37	\$1.50	\$9.02

### GROUND FREIGHT – TRUCKING

Ground freight requires palletization and does not deliver individual boxes. Less-than-truckload (LTL) shipments do not fill an entire trailer; full-truckload (FTL) shipments do. Ground freight offers flexible scheduling.

	Flat Fee	Direct Carrier Rate per Mile	Fuel Surcharge per Mile	Markup per Mile	Client Price per Mile
<b>Short-haul LTL (0-10 Miles)</b>	\$800.00	-	-	-	-
<b>LTL, Zone 1 (11-500 Miles)</b>	\$1,200.00	-	-	-	-
<b>LTL, Zone 2 (501-1,000 Miles)</b>	-	\$2.50	\$0.43	\$0.59	\$3.52
<b>LTL, Zone 3 (1,001+ Miles)</b>	-	\$2.55	\$0.44	\$0.60	\$3.59
<b>Short-haul LTL (0-10 Miles)</b>	\$800.00	-	-	-	-
<b>FTL, Zone 1 (11-500 Miles)</b>	\$1,500.00	-	-	-	-
<b>FTL, Zone 2 (501-1,000 Miles)</b>	-	\$2.45	\$0.42	\$0.57	\$3.45
<b>FTL, Zone 3 (1,001+ Miles)</b>	-	\$2.47	\$0.43	\$0.58	\$3.48

**\*\*Adding a liftgate is a \$250 upcharge for LTL services.**

## RAIL FREIGHT

Rail freight requires palletization and does not deliver individual boxes. Rail freight requires additional transportation to move shipments to and from rail yards.

Rail freight is on a fixed schedule.

	Flat Fee (Up to 24 Pallets)	Direct Carrier Rate per Mile	Fuel Surcharge per Mile	Markup per Mile	Client Price per Mile
<b>Closest Route: Birmingham, Alabama Rail Yard to Memphis, Tennessee Rail Yard</b>	\$544.00	-	-	-	-

## Transit Time Estimates

	Days in Transit
<b>Ground, Zone 1 (0-500 Miles)</b>	1-2
<b>Ground, Zone 2 (501-1,000 Miles)</b>	3-4
<b>Ground, Zone 3 (1,001+ Miles)</b>	5-6
<b>Two-day Air</b>	1-2
<b>Overnight Air (Must Ship by 1:00 p.m.)</b>	1
<b>Postal Service – Ground, Zone 1 (0-500 Miles)</b>	2
<b>Postal Service – Ground, Zone 2 (501-1,000 Miles)</b>	3-5
<b>Postal Service – Ground, Zone 3 (1,001+ Miles)</b>	6-7
<b>LTL, Zone 1 (0-500 Miles)</b>	1-2
<b>LTL, Zone 2 (501-1,000 Miles)</b>	2-3
<b>LTL, Zone 3 (1,001+ Miles)</b>	3-4
<b>FTL, Zone 1 (0-500 Miles)</b>	1
<b>FTL, Zone 2 (501-1,000 Miles)</b>	1-2
<b>FTL, Zone 3 (1,001+ Miles)</b>	2-3
<b>Rail, Zone 1 (0-500 Miles)</b>	2-3
<b>Rail, Zone 2 (501-1,000 Miles)</b>	4-5
<b>Rail, Zone 3 (1,001+ Miles)</b>	6-7

*\*\*Rail can include additional time waiting for scheduled departure times – this may be an additional one to four or more days.*

# Palletization Analysis

AIR FREIGHT (ONE ULD, ONE PRODUCT) BASED ON AN LD-3				
	Cartons per Pallet	Units per Carton	Units per Pallet	Load Weight in Pounds
Two-pack	150	12	1,800	273
ULD Weight				137
<b>Total Shipping Weight</b>				<b>410</b>
Four-pack	150	6	900	336
ULD Weight				137
<b>Total Shipping Weight</b>				<b>473</b>

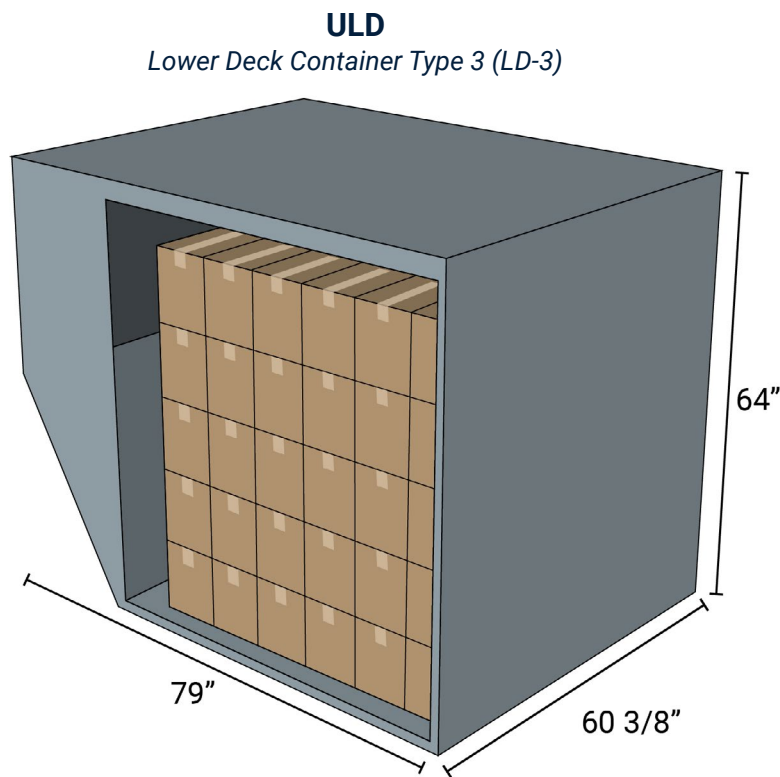

Palletization load analysis for one shipment:

- FTL will be best at 24 pallets.
- LTL will be one to 20 pallets.
- Air freight will be one to eight ULDs.

*\*\*Baseline estimates indicate Lumian sells an average of 240 pallets or 126,480 units per month, with an average of five outbound shipments sent to Lumian's retailers' distribution centers per week.*

# Warehouse Information

The Memphis, Tennessee Cumulo warehouse is 75,000 square feet and is open Monday through Saturday from 7 a.m. to 11 p.m. Floor storage can hold up to 250 single pallets or 500 double stacked pallets. Rack storage can hold 4,760 pallets and is a five-high system. The warehouse has six inbound dock doors and four outbound dock doors.

## Warehouse Floor Plan

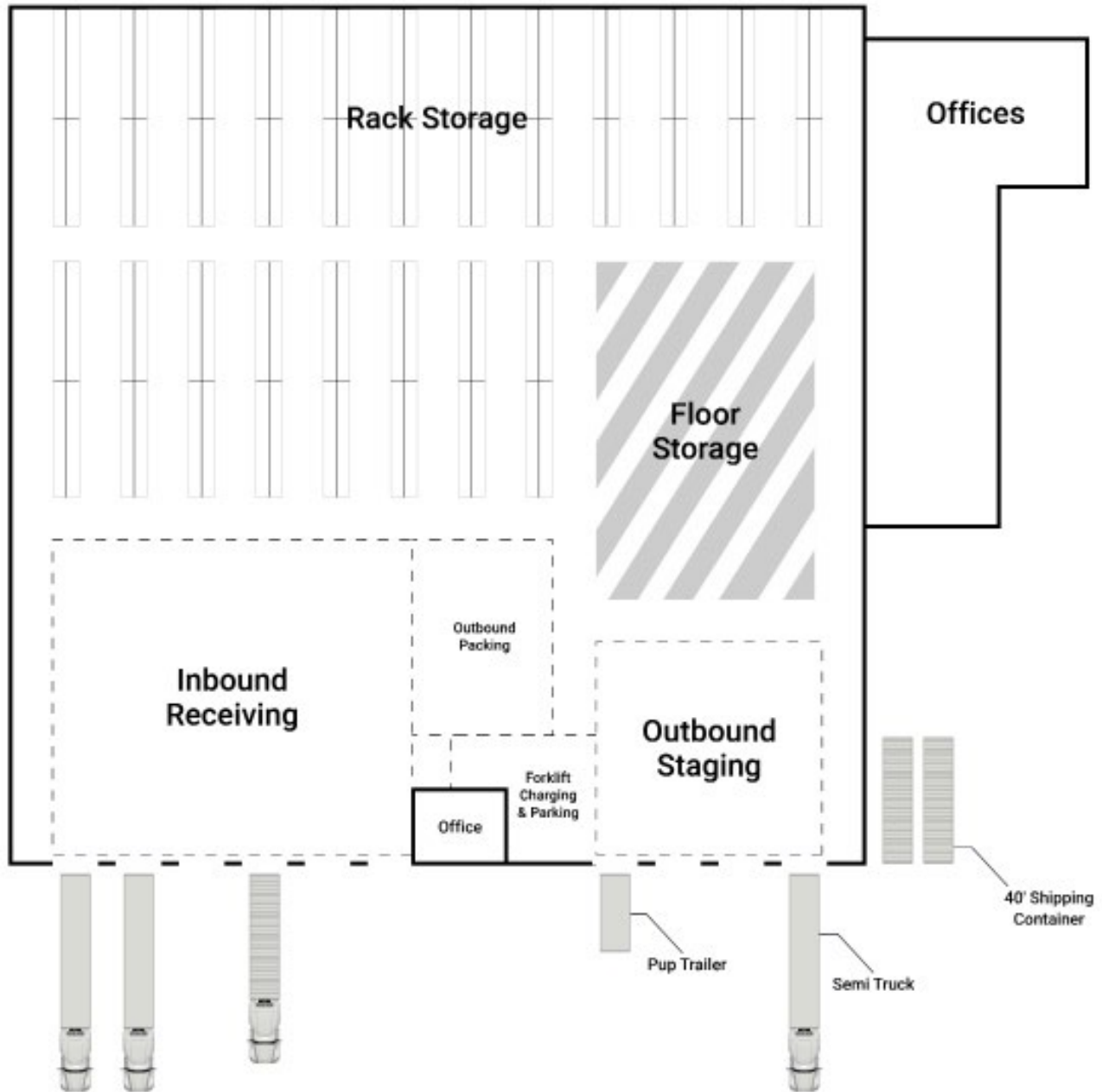

## Rack System

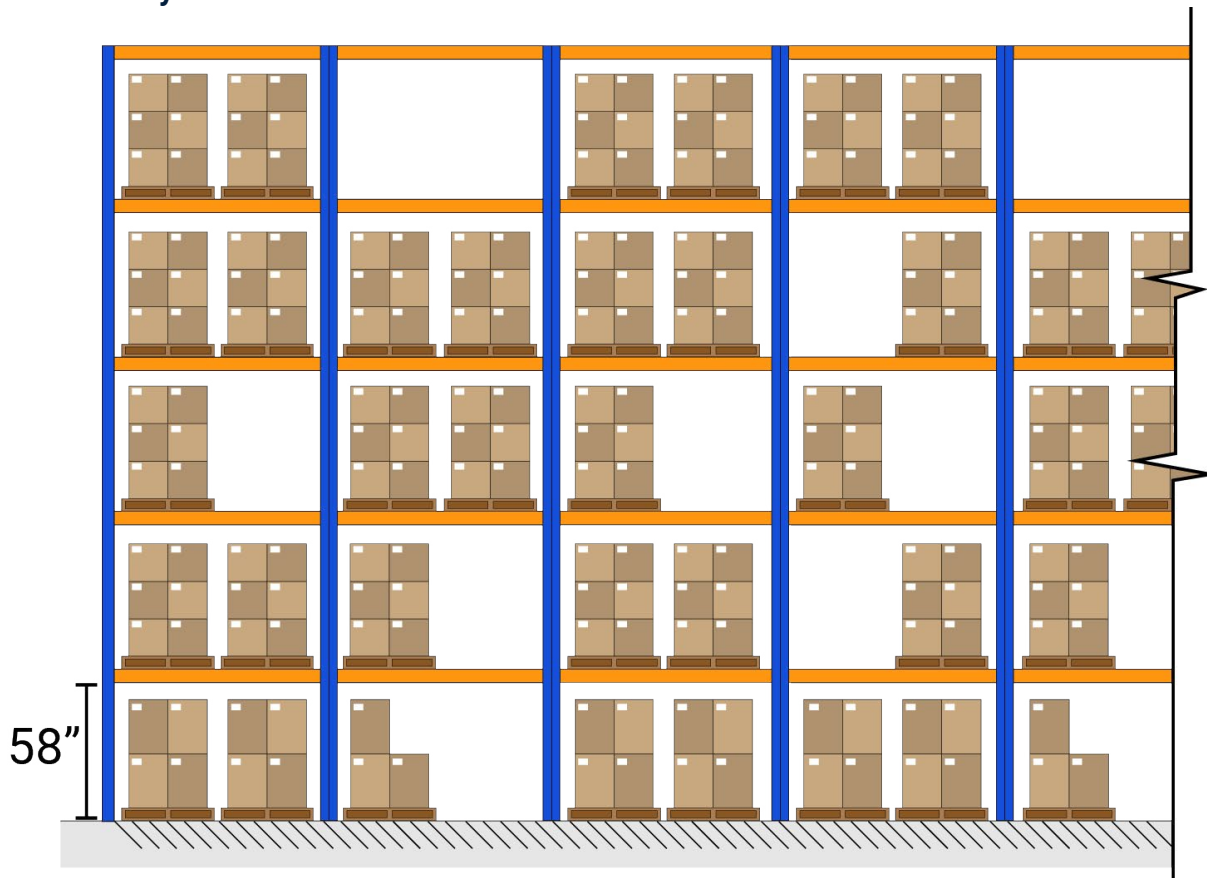

## Current Warehouse Utilization

	Current On-hand Pallets	Maximum On-hand Pallets Last Week
<b>Rack Storage</b>	3,113	3,370
<b>Single-stacked Floor Storage</b>	189	208
<b>Double-stacked Floor Storage</b>	26	24

## Warehousing Pricing

	Client Price per Pallet
<b>PALLET STORAGE</b>	
Single-stacked Floor Space	\$20.00
Double-stacked Floor Space	\$10.00
Rack Space	\$10.00
<b>PICK BINS OR PICK PALLETS</b>	
Level 1 Rack Space	\$10.00 (per pallet space)

*\*\*Cumulo charges clients on a weekly basis for warehouse utilization and bills for the maximum number of pallet spaces used during one week.*

## Handling Pricing

<b>INBOUND RECEIVING</b>	
	Client Price per Unit
Small Item (Maximum of 2 Pounds OR 12"x12"x6")	\$0.05
Medium Item (Maximum of 4 Pounds OR 18"x18"x12")	\$0.15
Large Item (Maximum of 65 Pounds OR Exceeds 18"x18"x12")	\$0.25
Oversized Item (Exceeds 65 Pounds OR Any Dimension Exceeds 48")	\$3.00

<b>OUTBOUND PICK AND PACK</b>	
	Client Price
Small Item (Maximum of 2 Pounds OR 12"x12"x6")	\$0.25 per unit
Medium Item (Maximum of 4 Pounds OR 18"x18"x12")	\$1.50 per unit
Large Item (Maximum of 65 Pounds OR Exceeds 18"x18"x12")	\$2.50 per unit
Whole Pallet	\$20.00 per pallet