

Cumulo Key Details

For internal use only



Freight Pricing Estimates

****The Buhi manufacturing plant in Cedar Rapids, Iowa is 552 miles from the Cumulo warehouse in Memphis, Tennessee. Additionally, Buhi's retailers' distribution centers are the in the following locations and are the provided distances from the Cumulo warehouse in Memphis:**

- Atlanta, Georgia: 420 miles
- Conklin, New York: 1,096 miles
- Goodyear, Arizona: 1,442 miles
- Macon, Georgia: 474 miles
- Plainfield, Indiana: 452 miles
- Prairie du Chien, Wisconsin: 652 miles
- Riverside, California: 1,758 miles
- Smithton, Pennsylvania: 775 miles
- Springfield, Missouri: 284 miles
- Tooele, Utah: 1,555 miles
- Wheeling, West Virginia: 713 miles

SMALL-PACKAGE FREIGHT

Small package is optimized for unpalletized, individual boxes going to individual customers. Small-package carriers deliver shipments directly to customers' doors.

	Base Fee (Up to 5 Pounds)	Direct Carrier Rate per Pound	Fuel Surcharge per Pound	Markup per Pound	Client Price per Pound
Ground	\$5.10	\$0.65	\$0.11	\$0.15	\$0.91
Two-day Air	\$12.25	\$3.75	\$0.83	\$0.92	\$5.50
Overnight Air	\$20.04	\$6.75	\$1.50	\$1.65	\$9.90
Postal Service – Ground (70-pound Maximum)	\$6.25	\$0.74	\$0.13	\$0.18	\$1.05

AIR FREIGHT

Air freight requires specialized containers, unit load devices (ULDs), or palletization that fits in the cargo-hold of an airplane. ULDs vary by airline carrier, making air freight a complex shipping option. Air freight requires additional transportation to move shipments to and from airports.

	Base Fee (Up to 250 Pounds)	Direct Carrier Rate per Pound	Fuel Surcharge per Pound	Markup per Pound	Client Price per Pound
Domestic Air Freight (One-pallet Minimum)	\$1,000.00	\$6.15	\$1.37	\$1.50	\$9.02

GROUND FREIGHT – TRUCKING

Ground freight requires palletization and does not deliver individual boxes. Less-than-truckload (LTL) shipments do not fill an entire trailer; full-truckload (FTL) shipments do. A full container load (FCL) shipment is a full intermodal shipping container that can be used on truck, ocean, and rail freight. Ground freight offers flexible scheduling.

	Flat Fee	Direct Carrier Rate per Mile	Fuel Surcharge per Mile	Markup per Mile	Client Price per Mile
Short-haul LTL (0-10 Miles)	\$800.00	-	-	-	-
LTL, Zone 1 (11-500 Miles)	\$1,200.00	-	-	-	-
LTL, Zone 2 (501-1,000 Miles)	-	\$2.50	\$0.43	\$0.59	\$3.52
LTL, Zone 3 (1,001+ Miles)	-	\$2.55	\$0.44	\$0.60	\$3.59
Short-haul LTL (0-10 Miles)	\$800.00	-	-	-	-
FTL, Zone 1 (11-500 Miles)	\$1,500.00	-	-	-	-
FTL, Zone 2 (501-1,000 Miles)	-	\$2.45	\$0.42	\$0.57	\$3.45
FTL, Zone 3 (1,001+ Miles)	-	\$2.47	\$0.43	\$0.58	\$3.48
Domestic, Short-haul FCL	\$500.00	-	-	-	-
FCL, Zone 1 (11-500 Miles)	\$1,500	-	-	-	-
FCL, Zone 2 (501-1,000 Miles)	-	\$2.45	\$0.42	\$0.57	\$3.45
FCL, Zone 3 (1,001+ Miles)	-	\$2.47	\$0.43	\$0.58	\$3.48
International, Short-haul FTL	\$1,200.00				
International, Short-haul LTL	\$1,000.00				

****Adding a liftgate is a \$250 upcharge for LTL services.**

RAIL FREIGHT

Rail freight requires palletization and does not deliver individual boxes. Rail freight requires additional transportation to move shipments to and from rail yards. Rail freight is on a fixed schedule.

	Flat Fee (Up to 24 Pallets or FCL)	Direct Carrier Rate per Mile	Fuel Surcharge per Mile	Markup per Mile	Client Price per Mile
Closest Route: Los Angeles, California to Memphis, Tennessee Rail Yard	\$2,710.00	-	-	-	-
Port of Long Beach in California to Memphis, Tennessee Rail Yard	\$2,500.00	-	-	-	-
Closest Route: Miami, Florida to Memphis, Tennessee Rail Yard	\$1,620.00	-	-	-	-
PortMiami in Florida to Memphis, Tennessee Rail Yard	\$1,500.00	-	-	-	-
Closest Route: Cedar Rapids, Iowa to Memphis, Tennessee Rail Yard	\$784.00	-	-	-	-

OCEAN FREIGHT

Ocean freight requires use of shipping containers and does not ship individual pallets. It also requires additional transportation to move shipments to and from ports. Ocean freight is on a fixed schedule, and ocean travel takes weeks.

	Flat Fee per FCL	Direct Carrier Rate per Mile	Fuel Surcharge per Mile	Markup per Mile	Client Price per Mile
Saigon Port in Vietnam to Port of Long Beach in California	\$4,500.00	-	-	-	-
Port of Caucedo in the Dominican Republic to Port of Miami in Florida	\$2,500.00	-	-	-	-

***Flat fees include drayage freight to move shipping containers from the manufacturing plant to the port.*

Transit Time Estimates

	Days in Transit
Ground, Zone 1 (0-500 Miles)	1-2
Ground, Zone 2 (501-1,000 Miles)	3-4
Ground, Zone 3 (1,001+ Miles)	5-6
Short Haul	Less than 1
Two-day Air	1-2
Overnight Air (Must Ship by 1:00 p.m.)	1
Postal Service – Ground, Zone 1 (0-500 Miles)	2
Postal Service – Ground, Zone 2 (501-1,000 Miles)	3-5
Postal Service – Ground, Zone 3 (1,001+ Miles)	6-7
LTL, Zone 1 (0-500 Miles)	1-2
LTL, Zone 2 (501-1,000 Miles)	2-3
LTL, Zone 3 (1,001+ Miles)	3-4
FCL/FTL, Zone 1 (0-500 Miles)	1
FCL/FTL, Zone 2 (501-1,000 Miles)	1-2
FCL/FTL, Zone 3 (1,001+ Miles)	2-3
Rail, Zone 1 (0-500 Miles)	2-3
Rail, Zone 2 (501-1,000 Miles)	4-5
Rail, Zone 3 (1,001+ Miles)	6-7
Ocean, Southeast Asia to United States	28-42
Ocean, Caribbean to United States	14-28

***Rail can include additional time waiting for scheduled departure times – this may be an additional one to four or more days.*

Palletization Analysis

AIR FREIGHT (ONE ULD, MIXED PALLET) BASED ON AN LD-3				
	Cartons per Pallet	Units per Carton	Units per Pallet	Load Weight in Pounds
Small Backpack	3	8	24	14.94
Medium Backpack	15	4	60	60.0
Large Backpack	8	4	32	53.92
Messenger Bag	12	4	48	106.8
Tote Bag	1	20	20	11.07
Hip Pack	1	16	16	9.94
Total	40	-	200	256.67
ULD Weight				137
Total Shipping Weight				393.67

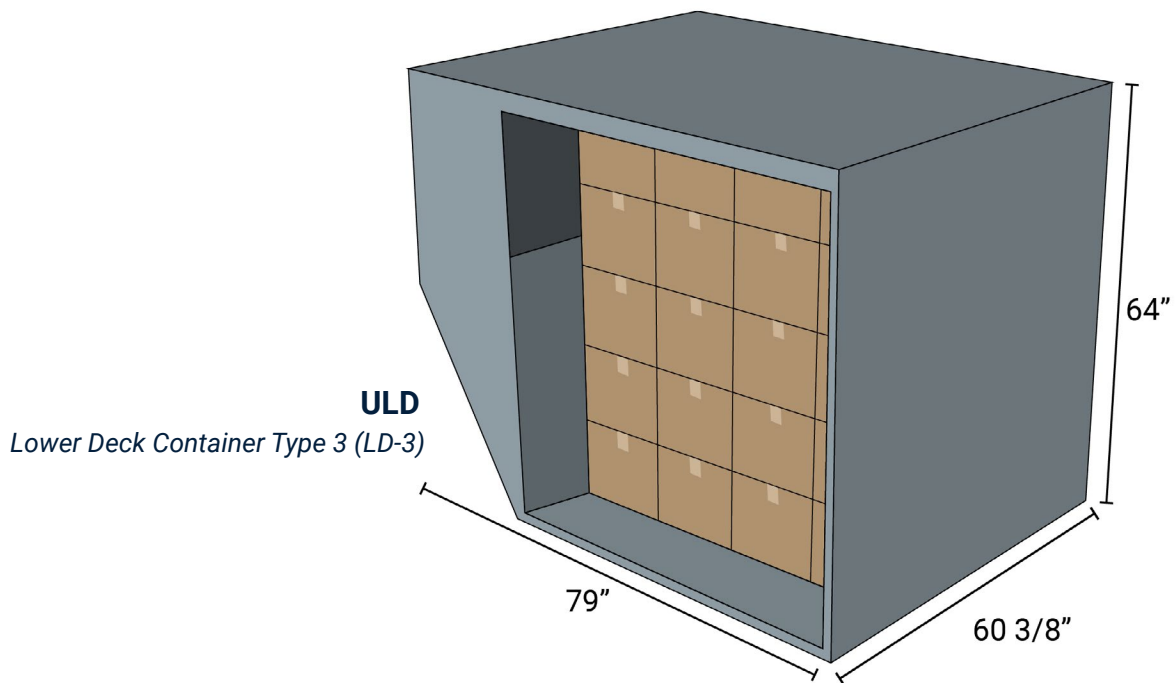

Palletization load analysis for one shipment:

- FTL will be best at 24 pallets.
- LTL will be one to 20 pallets.
- FCL will have 20 pallets.
- Air freight will be one to eight ULDs.

***Baseline estimates indicate Buhi sells an average of 25,822 units per month to customers and 173 pallets per month to retailers. Outbound shipments to Buhi's retailers' distribution centers will be sent at different intervals, some every four weeks and others every six to eight. About 1,076 outbound shipments will be sent per day to customers.*

Warehouse Information

The Memphis, Tennessee Cumulo warehouse is 75,000 square feet and is open Monday through Saturday from 7 a.m. to 11 p.m. Floor storage can hold up to 250 single pallets or 500 double stacked pallets. Rack storage can hold 4,760 pallets and is a five-high system. The warehouse has six inbound dock doors and four outbound dock doors.

Warehouse Floor Plan

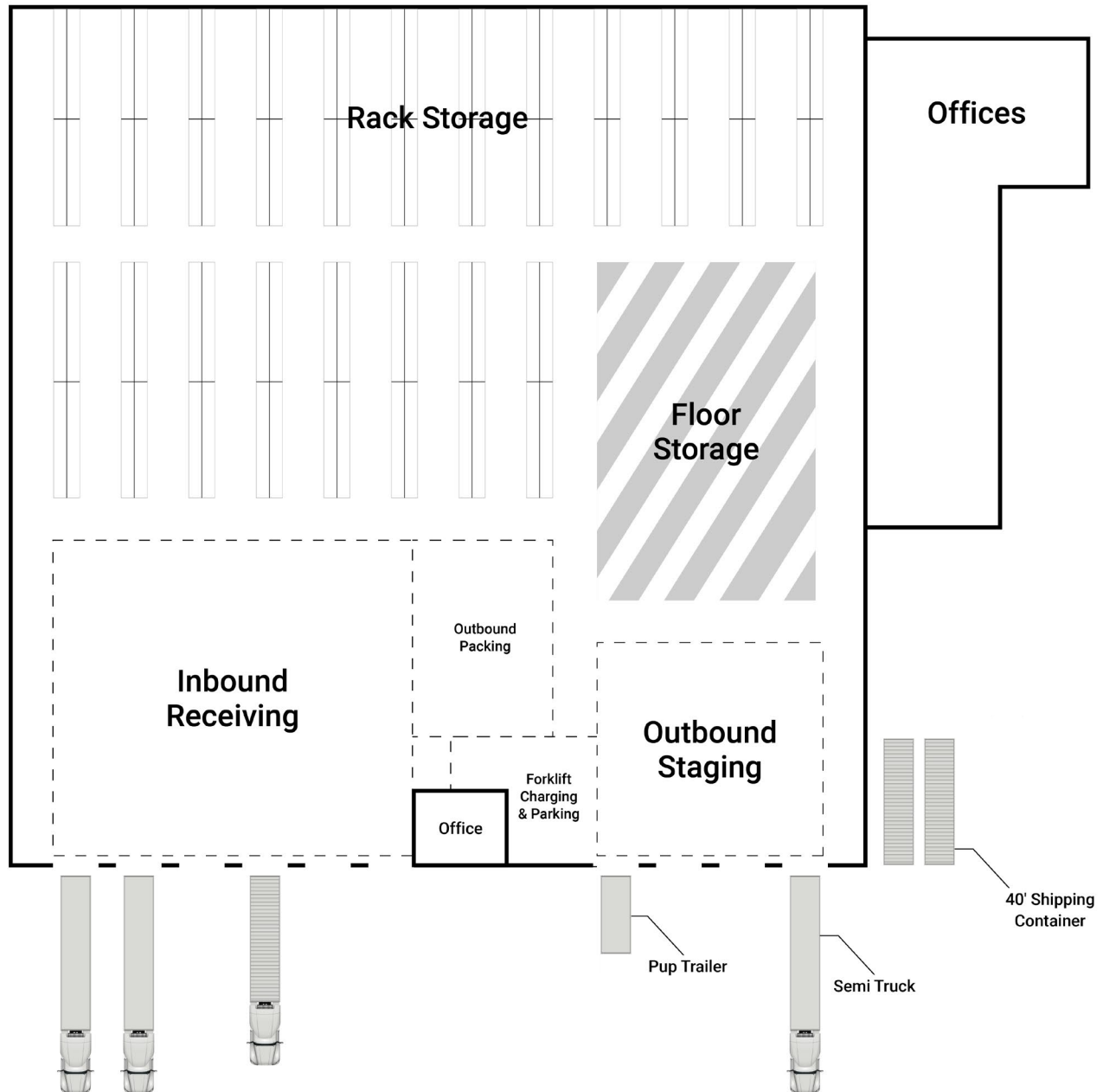

Rack System

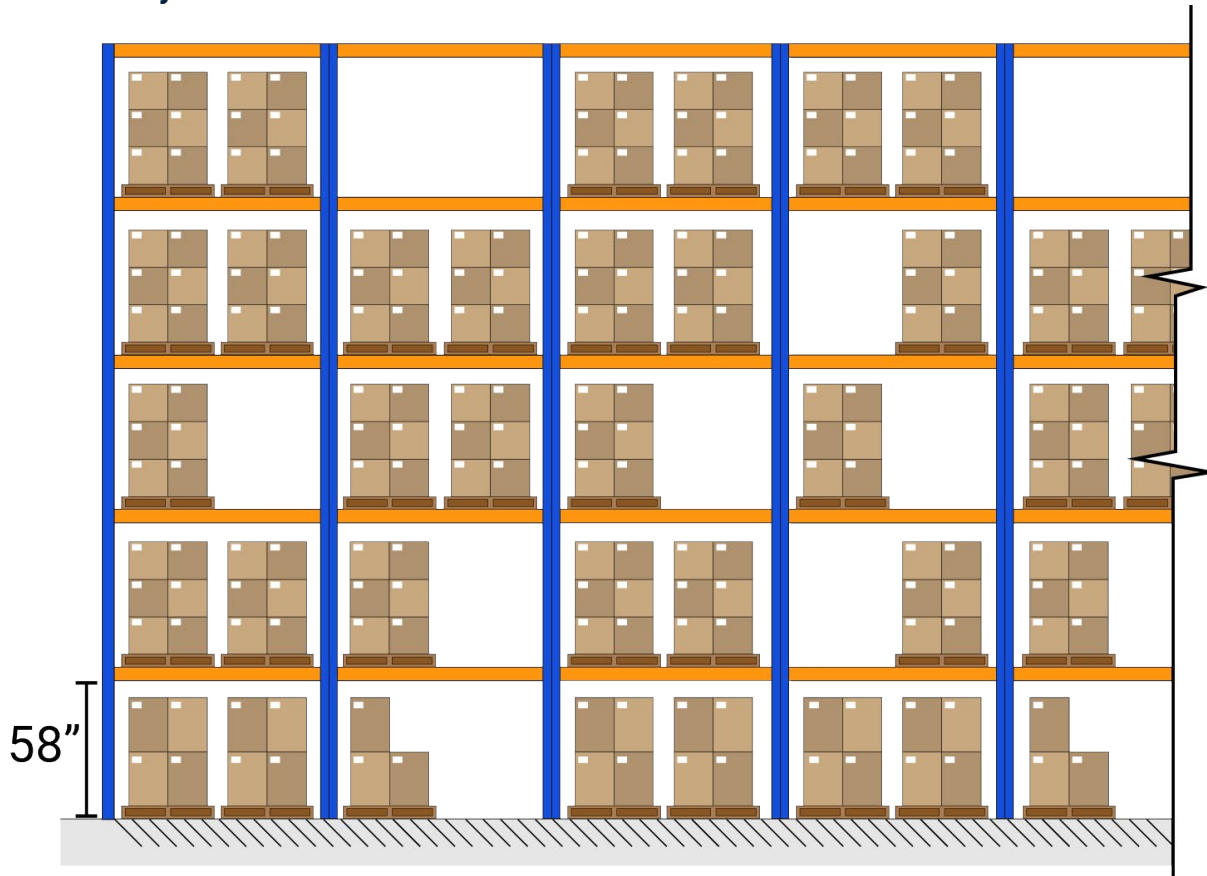

Current Warehouse Utilization

	Current On-hand Pallets	Maximum On-hand Pallets Last Week
Rack Storage	3,115	3,236
Single-stacked Floor Storage	171	197
Double-stacked Floor Storage	18	26

Warehousing Pricing

	Client Price per Pallet
PALLET STORAGE	
Single-stacked Floor Space	\$20.00
Double-stacked Floor Space	\$10.00
Rack Space	\$10.00
PICK BINS OR PICK PALLETS	
Level 1 Rack Space	\$10.00 (per pallet space)

***Cumulo charges clients on a weekly basis for warehouse utilization and bills for the maximum number of pallet spaces used during one week.*

Handling Pricing

INBOUND RECEIVING	
	Client Price per Unit
Small Item (Maximum of 2 Pounds OR 12"x12"x6")	\$0.05
Medium Item (Maximum of 4 Pounds OR 18"x18"x12")	\$0.15
Large Item (Maximum of 65 Pounds OR Exceeds 18"x18"x12")	\$0.25
Oversized Item (Exceeds 65 Pounds OR Any Dimension Exceeds 48")	\$3.00

OUTBOUND PICK AND PACK	
	Client Price
Small Item (Maximum of 2 Pounds OR 12"x12"x6")	\$0.25 per unit
Medium Item (Maximum of 4 Pounds OR 18"x18"x12")	\$1.50 per unit
Large Item (Maximum of 65 Pounds OR Exceeds 18"x18"x12")	\$2.50 per unit
Whole Pallet	\$20.00 per pallet